



LAUNCH
IGNITE INNOVATION



“BEYOND
PRODUCT
DESIGN,

THE FUTURE IS
THE *PRODUCT*
EXPERIENCE.”

OUR APPROACH

Functionality, Usability, Brand, Design, Quality, and Price = Product Experience.

The most successful products will offer a competitive balance of these elements. We start by understanding the gap between the experience consumers are offered today, and the one they aspire to have.

Through that understanding, we can develop a product design strategy that defines a successful experience. That becomes the measuring stick that we use to guide our development. From opportunity space to manufactured parts, we have a suite of tools that are proven to work.

You can't build a skyscraper without pouring a solid foundation. **Let us help you achieve your goals by launching product experiences that delight consumers and build loyalty to your brand.**

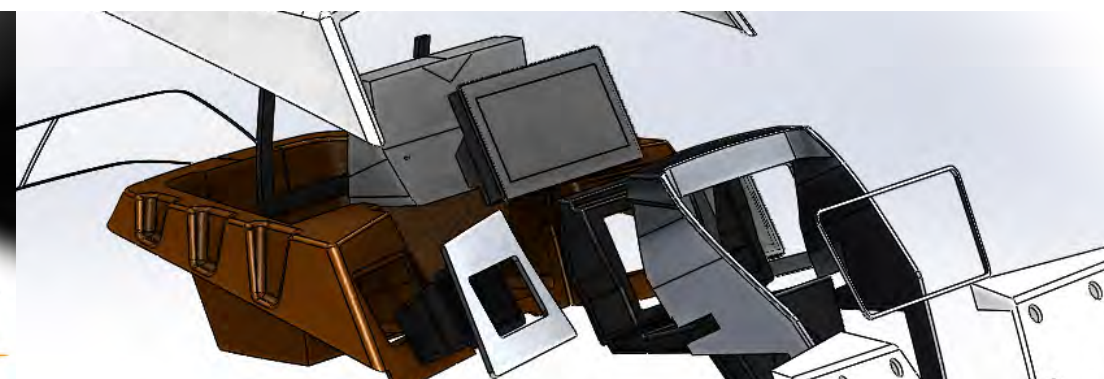
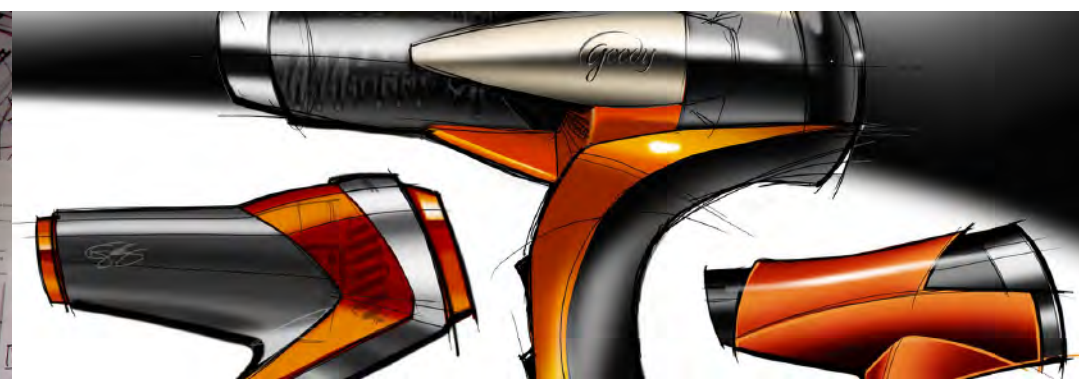

BUILDING THE EXPERIENCE

To get to the right solution, you need the right process

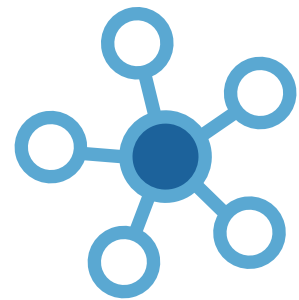

STAKEHOLDER VOICES

1

Competing Viewpoints

Uncovering the gaps between the experience consumers are having, and the one they are craving.

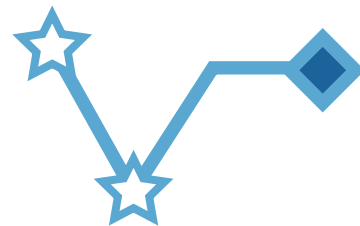

CONNECT TO DEVELOP

2

Partner with Experts

Identify technology partnership opportunities to expedite development.



GUARDRAILS

3

Design Your Strategy

Marketplace analysis to define a differentiated product experience.

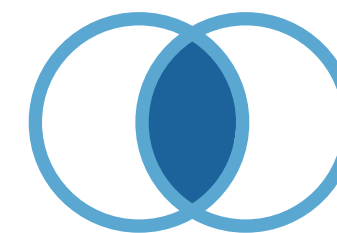

PRODUCT DESIGN

4

Design Signature

Intersecting the product experience with core brand values.

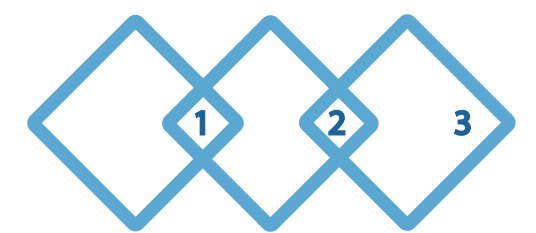

DEVELOP & REFINE

5

Plan and Measure Progress

A measuring stick for cross functional balance and deliverables

SUCCESS BY DESIGN

Launch has created and enhanced experiences, products, and brands for diverse clients across various industries

HARRIS

Char-Broil

GP
Georgia-Pacific

Chick-fil-A

Rubbermaid

HONEYBAKED

Herman Miller

TW

Newell Rubbermaid

CENTRAL
Garden & Pet

BRUNSWICK

Goody

Steelcase

DeckMate
Boat Seats

STEALTH
Quick Release Rod Holders

Calphalon

BISSELL

Amerock

DIGITAL EXPERIENCE

BRING THE DIGITAL EXPERIENCE TO MARINE

Technology and style infused into the pontoon boat. With large digital touchscreen displays (12" and 7") eliminating the need of countless switches and gauges, it has never been easier to enjoy and navigate the water. Personal device chargers and inputs have been incorporated, as well as water tight storage for that device and other personal items.



SAVE TIME

BIOMIMICRY FAN TECH DRIES HAIR 50% FASTER

Utilizing PAX biomimicry technology, the Goody Flash Dryer is able to generate the airflow of a commercial grade AC motor using a much less expensive DC motor. The result is a mass market hairdryer that can reduce styling times dramatically.



ONE HANDED

REPLACE THE PUMP ONE HANDED WITH EYES CLOSED

Available in 3 color coded sizes, Attwood Tsunami bilge pumps allow the user to quickly detach the motor cartridge with one hand, and without having to actually see the pump. The intuitive grip design provides bold tactile feedback that allows the user to orient and replace new motor cartridges.



ACTIVE STYLE

DRINK WITH A FASHION STATEMENT

The drink bottle has become an everyday item. We carry them around at work, in our cars, at the gym, or at home. The lowly cup or bottle has now been elevated to a fashion statement. Choose from a full line of water and insulated bottles for any active style.



ALWAYS SHARP

CREATE KNIVES THAT ALWAYS STAY SHARP

Calphalon delivered a new Classic Cutlery line that includes a self sharpening system incorporated into the block. Now, every time a knife is removed and replaced, it is sharpened, eliminating the constant need for hand sharpening. The user experience is elevated through enhanced design and ergonomics. Careful attention was paid to the balance of the knife, the feel of the handle, and a design that promotes proper usage and safety.



NEVER WET

CREATE A BOAT SEAT THAT DRIES INSTANTLY

Nobody likes a wet seat. Visionair offers a pellicle seating surface that is gentle on the skin and UV resistant. It also offers ergonomic comfort, natural suspension and allows water to pass through it, so that it never feels wet or retains water. The exterior of the seat features modular, low-cost components that can be swapped to uniquely brand dress the technology for any OEM boat manufacturer.



DESIGN SIGNATURE



BRANDED TOUCH-POINTS

Consumers choose window coverings based on fashion. By focusing on key touch-points, the consumer experience can be consistently elevated to support the brand promise.

BRAND DRIVEN

BRANDED DESIGN BEYOND BEVERAGES

Leveraging the Tecate design Language to extend the brand into a supporting family of products. Through the use of strong angles, large touch-points, and durable materials, the result was the embodiment of their design language.



FUNCTIONAL STYLE

LOWER COST THROUGH A SIMPLE SIGNATURE DESIGN

Through reduced parts, modular construction and logical escalation of materials and features, Goody can drive brand consistency into their most competitively priced products.



RIGHT SPACE



CREATE AN EFFICIENT, USABLE PLATFORM

Most dish drying racks are not made for the correct purpose. They are actually used for items that don't fit, or can't be put into dishwashers but competitors have the racks configured for common dishes and glasses. This is why the Rubbermaid dish dryer has modular space for large items like cutting boards and pots, as well as space for wine glasses and other odd shaped items.

ACCESSIBLE STYLE

QUALITY MATERIALS AND FINISHES AT A LOWER COST

Most drapery hardware in retail stores has moved to painted finishes and resin construction. With clever design consideration, material reduction, and supplier engagement, finials could be offered in metal with fantastic plated finishes for only a small premium. The quality difference at point of purchase was evident.



INSTANT CUSTOMIZATION

AUTOMATED IN-STORE WINDOW BLIND CUTTING

Transforming a skilled service into a fully automated experience that enhances the Levolor brand and dramatically reduces operator error. With the Levolor Smart Machine, the solution meant redesigning the experience for the associate and consumer. The results are reduced customer frustration in store and at home, lower returns, and increased sales.



NO TANGLES

ORGANIZE CORD CHAOS

A simple, inexpensive solution that can absorb up to 16 feet of cords quickly and easily.



MOVE OVER

ECENTRIC PIVOT MECHANISM CREATES SPACE

By moving the seat away from the gunwale during rotation, it allows helm controls and features to be brought closer to the seat. Creating the opportunity for a more automotive feeling cockpit.



MOVE FASTER

SCOOP ICE IN 1/3 THE TIME

Scooping ice is hard on the back and time consuming. The Rubbermaid Commercial Food Scovel solves for this by extending the users reach and holding four times as much ice as a conventional scoop.



NO SNAGS

ELIMINATING PINCH POINTS THAT PULL HAIR

When bristles are flexed during use, gaps open and close where the bristle meets the pad. These gaps grab and pull hair causing pain and damage. By hiding the intersections beneath the brush face, they are hidden, creating a pain and damage free experience.



ULTIMATE CONTROL

SECURITY IN ONE MOTION RELEASE

The Stealth QR-1 features an elastomer cam system that grips the rod handle. It allows the angler to control rod position, it eliminates down line vibration that spooks fish and, it releases only when pulled upward.



SIMPLY LIGHT

COMMERCIAL POWER IN UNDER 8 LBS.

Dual air-path suction , 30 foot cord,
and concealed headlamp that illumi-
nates as it leans back into the use
position. This commercial grade
vacuum was designed to compete in
direct sales and commercial spaces.



FULLY ADJUSTABLE

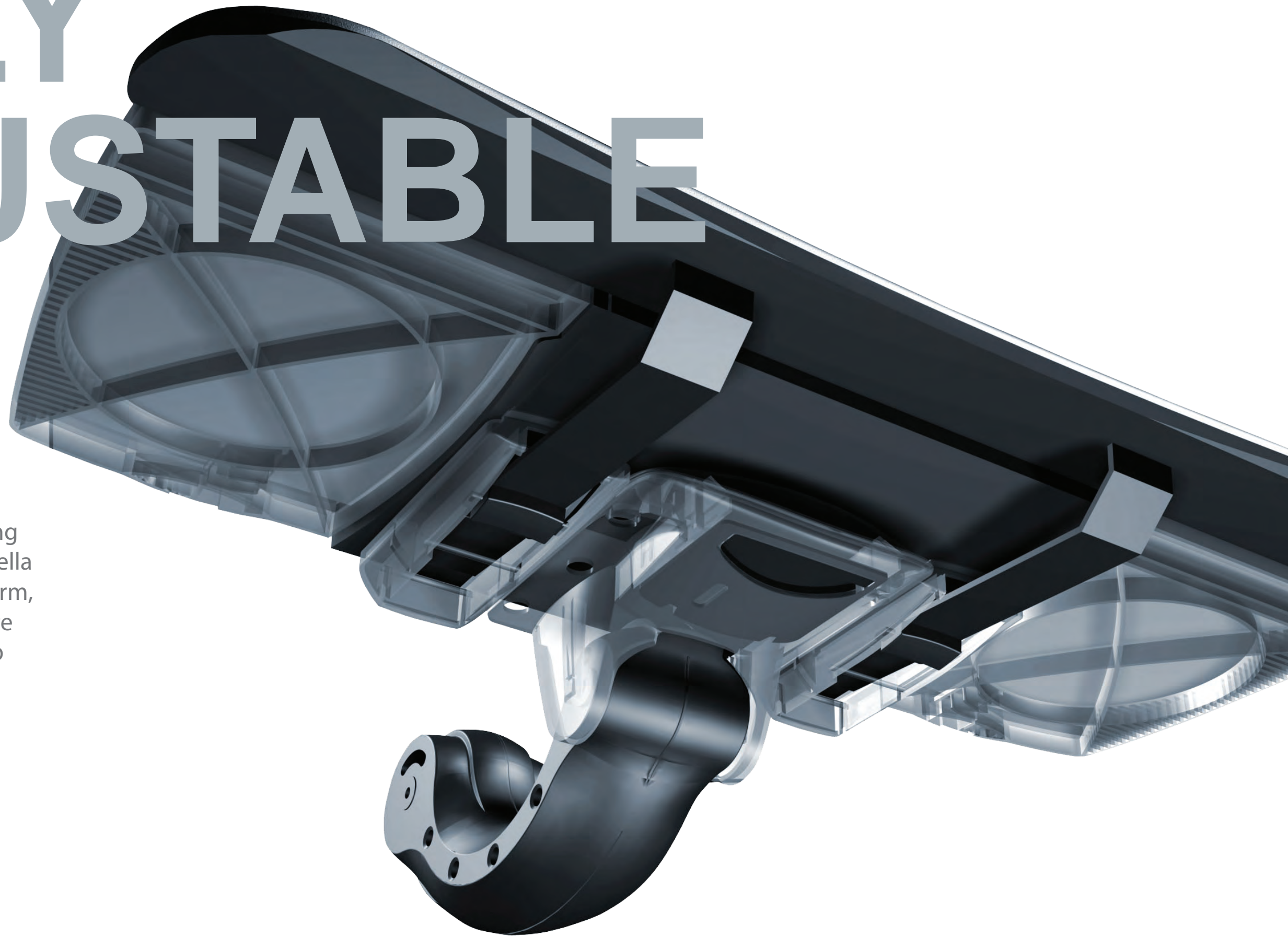

BIG FEATURES IN A STREAMLINED PACKAGE

Keyboard tools are useful but consume a lot of space. By streamlining mechanisms and interfaces, the Stella Mechanism and Equilibrium Platform, for Steelcase Details, offer complete customization without banging up your knees.

TECHNOLOGY INSIDE

PRODUCT DESIGN REFLECTING HIDDEN TECHNOLOGY

Calphalon Precision Cookware leverages thin film heating technology that helps create a faster and more efficient experience. Featuring a lower profile design that suggests new and different, accompanied by a digital touch interface. Consumers can interact with the technology and quickly realize the performance benefits.



STOW AWAY

A CLEAT THAT IS FLUSH WHEN NOT IN USE

Cleats are dangerous. By allowing the cleat to pop up and down there is no loss of functionality, as boats become safer and more streamline. Originally a premium upgrade, these cleats are quickly becoming standard because of the clear safety benefit and modern look.



NEW STANDARD

RE-INVENTING FOLDING FINISHING SEATS

Metal hinges are dangerous. By creating an ergonomic seat core with an integrated center hinge, folding seats are now safer as well as more comfortable and refined. This seat is now standard among top fishing boat manufacturers.



MAXIMIZE TRENDS

USING CURRENT TRENDS TO MAKE AN IMPACT

Current trends make a considerable impact to any decor portfolio that already has a collection of timeless designs. This is true for Amerock's decorative cabinet hardware where trendy new designs create needed attention and buzz.



BEAUTIFULLY DIFFERENT

MAKING TECHNOLOGY TRANSPARENT

Goody Flash Dry Technology was developed in concert with PAX bio-mimicry experts to generate more power using commodity components. The difficulty is that all of this is hidden internally. Flash CLR allows the technology to be seen while remaining functionally beautiful, key for this market.



WHAT
WILL
YOU
LAUNCH



704.453.6638

LaunchProductDesign.com

Info@LaunchProductDesign.com